



# ROITHNER LASERTECHNIK GmbH

WIEDNER HAUPTSTRASSE 76  
TEL. +43 1 586 52 43 -O. FAX. -44

1040 VIENNA AUSTRIA  
OFFICE@ROITHNER-LASER.COM



## C34L5111A

- Light Emitting Diode
- Cyan color tone
- InGaN structure
- 5 mm clear epoxy package



### Description

**C34L5111** is an **InGaN** based LED with a phosphorous coating, emitting a **cyan light** of high luminous intensity (25 cd). It comes in a hermetically sealed clear 5 mm UV resistant epoxy resin.

### Maximum Rating ( $T_{CASE} = 25^{\circ}C$ )

Parameter	Symbol	Values		Unit
		Min.	Max.	
Power Dissipation, DC	$P_D$		102	mW
DC Forward Current*	$I_F$		30	mA
Pulse Forward Current*	$I_{FP}$		100	mA
Reverse Voltage	$V_R$		5.0	V
Operating Temperature	$T_{OPR}$	- 30	+ 85	$^{\circ}C$
Storage Temperature	$T_{STG}$	- 40	+ 100	$^{\circ}C$
Soldering Temperature (max 5s)	$T_{SOL}$		+ 260	$^{\circ}C$

\* Duty cycle max. 10%, Pulse width max 10ms

### Electro-Optical Characteristics ( $T_{CASE} = 25^{\circ}C$ , $I_F = 20$ mA)

Parameter	Symbol	Values			Unit
		Min.	Typ.	Max.	
Chromaticity Coordinates	x		0.208		
	y		0.256		
Forward Voltage	$V_F$	2.7	2.9	3.4	V
Reverse Current ( $V_R = 5V$ )	$V_R$			10	$\mu A$
Luminous Intensity	$I_V$	22	25		cd
Luminous Flux	$\Phi_V$	6.0	6.7		lm
Viewing Half Angle	$\Theta_{1/2}$		7.5		deg.

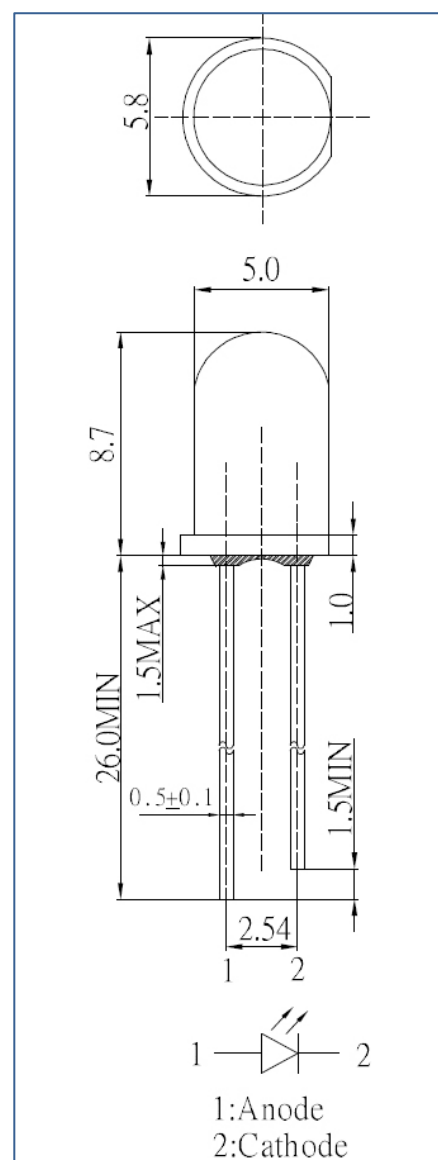

All dimensions in mm



## Performance Characteristics

Forward Current vs. Forward Voltage

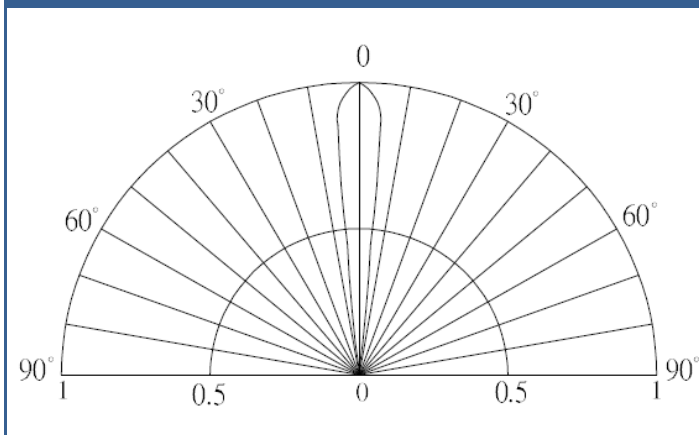

Relative spectral distribution vs. Wavelength

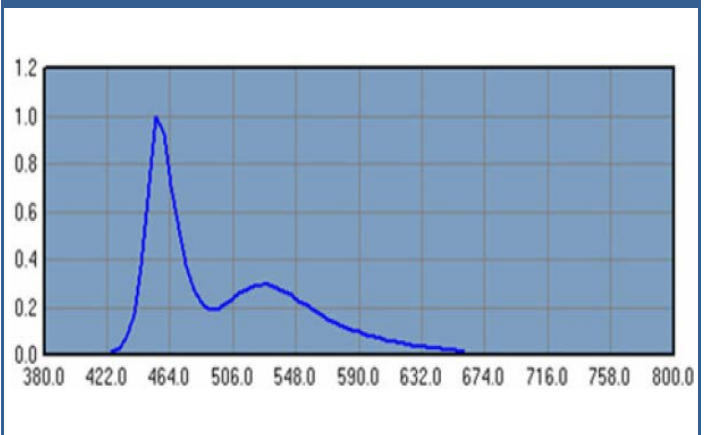

© All Rights Reserved

The above specifications are for reference purpose only and subjected to change without prior notice