



SPL1064-30-6-PD

- Infrared Fiber-Coupled Laser Diode
- 1064 nm, 30 mW
- 6 μm Single Mode Fiber
- Built-in Photodiode



Description

SPL1064-30-6-PD is an infrared fiber-coupled laser diode, typically emitting at 1064 nm with an output power of 30 mW. It comes in a coaxial package with a mounting bracket, with 6 μm single mode fiber, FC/PC connector and built-in PD.

Additional options like closer peak wavelength selection or alternative fiber connector are available on request.

Maximum Rating ($T_{\text{CASE}} = 25^{\circ}\text{C}$)

Parameter	Symbol	Values		Unit
		Min.	Max.	
Reverse Voltage	V_R		2.0	V
PD Reverse Voltage	V_{PD}		30	V
Operating Temperature	T_{OPR}	- 10	+ 50	$^{\circ}\text{C}$
Storage Temperature	T_{STG}	- 40	+ 85	$^{\circ}\text{C}$
Soldering Temperature (max. 3s)	T_{SOL}		+ 260	$^{\circ}\text{C}$

Electro-Optical Characteristics ($T_{\text{CASE}} = 25^{\circ}\text{C}$)

Parameter	Symbol	Values			Unit
		Min.	Typ.	Max.	
Peak Wavelength *1	λ_P	1049	1064	1079	nm
Output Power	P_O		30		mW
Spectral Width (FWHM)	$\Delta\lambda$				nm
Operating Voltage	V_F		1.8	2.5	V
Threshold Current	I_{th}		20	55	mA
Operating Current	I_F		260	280	mA
PD Current	I_{PD}		0.2		mA
Fiber Specification	Type	Single Mode			
	Core	6			μm
	Connector *2	FC/PC			
	Length	80	100		cm



*1 optional: down to ± 10 nm

*2 optional: SC or SMA905



Electrical Connection

Pin Configuration*

PIN #	Function
1	LD Cathode
2	LD Anode, PD Cathode
3	PD Anode

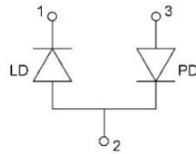

Bottom View

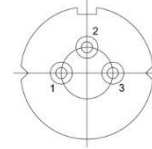

* subject to change

Outline Dimension

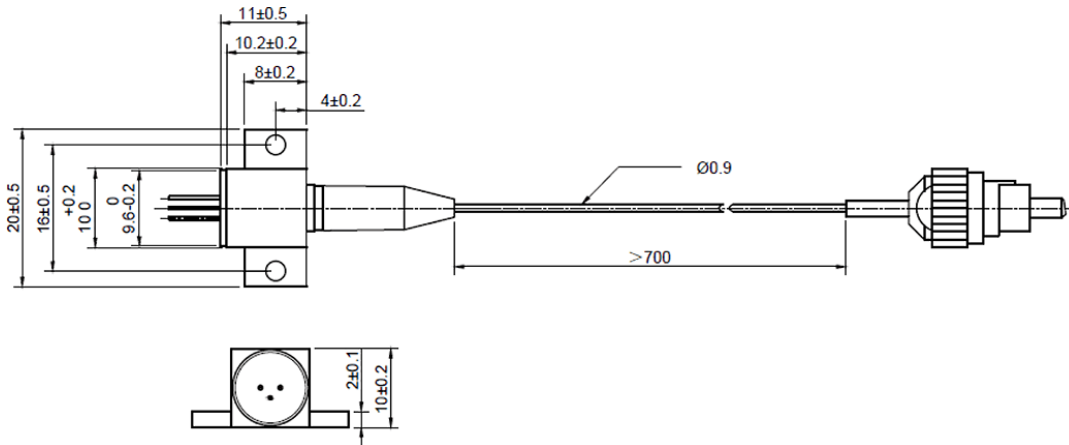

All dimensions in mm



Precautions

Safety

Caution: Laser light emitted from any laser diode may be harmful to the human eye. Avoid looking directly into the laser diode's aperture when the diode is in operation.

Note: The use of optical lenses with this laser diode will increase eye hazard



ESD Caution

Always do handle laser diodes with extreme care to **prevent electrostatic discharge**, the primary cause of unexpected diode failure. To prevent ESD related failures we strongly advise to always **wearing wrist straps**, and **grounding all applicable work surfaces**, when handling laser diodes



Operating Considerations

We strongly advise to only operate this laser diode with a current source. The current of a laser diode is an exponential function of the voltage across it. **Usage of current regulated drive circuits is mandatory.**

Laser diodes may be damaged by excessive drive currents or switching transients

It is advised, to operate the laser diode at the lowest temperature possible, and to never exceed maximum specifications as outlined in the datasheet. Device degradation will accelerate with increased temperature. **Proper heat sinking will greatly enhance stability and life-time of the laser diode.**