



SMT735

High Performance Infrared TOP IR LED

SMT735 consists of an AlGaAs LED mounted on the lead frame as TOP LED package and is 10mW typical of output power.

It emits a spectral band of radiation at 735nm.

Specifications

- | | |
|---------------------|---------------|
| 1) Product Name | TOP IR LED |
| 2) Type No. | SMT735 |
| 3) Chip | |
| (1) Chip Material | AlGaAs |
| (2) Peak Wavelength | 735nm typ. |
| 4) Package | |
| (1) Lead Frame Die | Silver Plated |
| (2) Package Resin | PPA Resin |
| (3) Lens | Epoxy Resin |

Outer dimension(Unit:mm)

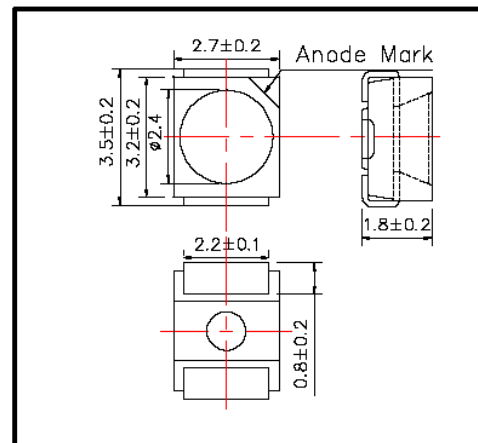

Absolute Maximum Rating

Item	Symbol	Maximum Rated Value	Unit	Ambient Temperature
Power Dissipation	P _D	100	mW	T _a =25°C
Forward Current	I _F	50	mA	T _a =25°C
Pulse Forward Current	I _{FP}	200	mA	T _a =25°C
Reverse Voltage	V _R	5	V	T _a =25°C
Operating Temperature	T _{OPR}	-20 ~ +80	°C	
Storage Temperature	T _{STG}	-30 ~ +80	°C	
Soldering Temperature	T _{SOL}	240	°C	

‡Pulse Forward Current condition: Duty=1% and Pulse Width=10us.

‡Soldering condition: Soldering condition must be completed within 3 seconds at 260°C

Electro-Optical Characteristics [T_a=25°C]

Item	Symbol	Condition	Minimum	Typical	Maximum	Unit
Forward Voltage	V _F	I _F =50mA		1.90	2.30	V
Reverse Current	I _R	V _R =5V			10	uA
Total Radiated Power	P _O	I _F =50mA	5.0	10.0		mW
Radiant Intensity	I _E	I _F =50mA	2.0	5.0		mW/sr
Peak Wavelength	λ _P	I _F =50mA		735		nm
Half Width	Δλ	I _F =50mA		20		nm
Viewing Half Angle	Q _{1/2}	I _F =50mA		±55		deg.
Rise Time	t _r	I _F =50mA		80		ns
Fall Time	t _f	I _F =50mA		80		ns

‡Total Radiated Power is measured by Photodyne #500

‡Radiant Intensity is measured by Tektronix J-6512.