



TOLATB004

Reflector LED

1. SPECIFICATIONS

1- 1. Absolute Maximum Ratings (Ta=25°C)

Item	Symbol	Absolute Maximum Rating	Unit
Forward Current	I _F	30	mA
Reverse Voltage	V _R	5	V
Power Dissipation	P _D	105	mW
Operating Temperature	T _{opr}	-30~+85	°C
Storage Temperature	T _{stg}	-30~+90	°C

I_{FP} Conditions ; Pulse Width ≤ 100 μsec. , Duty ≤ 1/100

1- 2. Electrical / Optical Characteristics (Ta=25°C)

Item	Symbol	Condition	Min.	Typ.	Max.	Unit
Forward Voltage	V _F	I _F =20mA	-	3.0	3.5	V
Reverse Current	I _R	V _R =5V	-	-	10	μA
Dominant Wavelength	λ _d	I _F =20mA	460	470	480	nm
Spectrum Half Width	Δλ	I _F =20mA	-	22	-	nm
Luminous Intensity	I _v	I _F =20mA	-	30	-	cd
Viewing Angle	1/2 θ	I _F =20mA	-	±10	-	°

2. Directivity (Typical) (Ta=25°C)

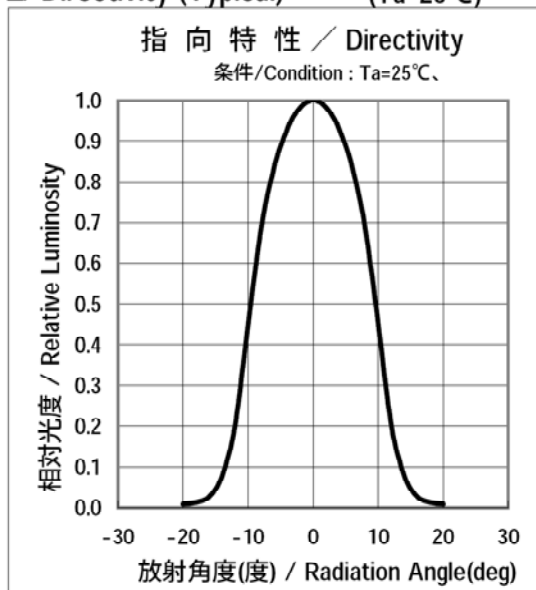

3. Outline Dimensions

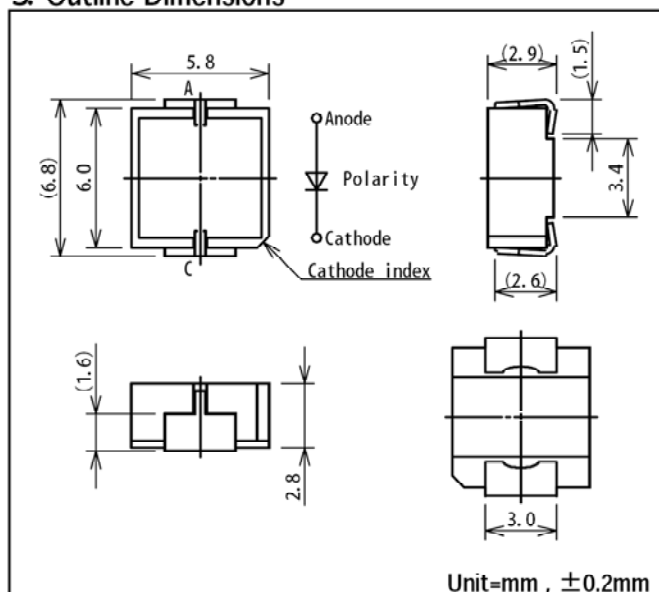



Typical Performance Curves

