



B56L511P

TECHNICAL DATA



Visible LED 5 mm, InGaN

Features

- High Luminous LEDs
- 5mm Round Standard Directivity
- Long Lifetime Operation
- Superior Weather-resistance
- UV Resistant Epoxy
- Water Clear Type

Applications

- Automotive Dashboard Lighting
- Traffic Signal Lamp
- Back Lighting
- Other Lighting

Directivity:

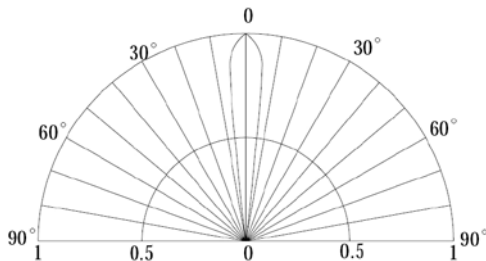

Outline Dimension:

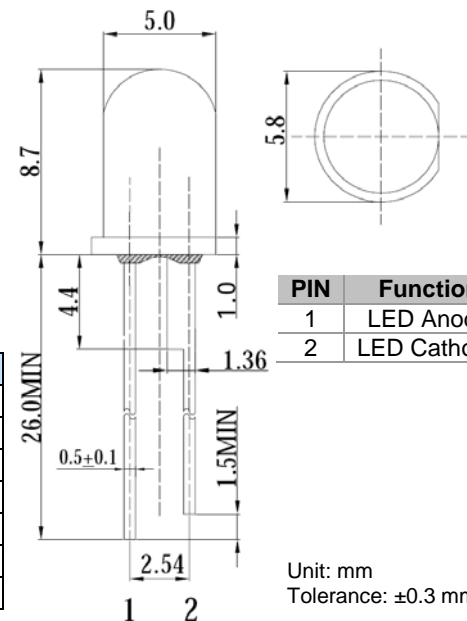

PIN	Function
1	LED Anode
2	LED Cathode

Absolute Maximum Ratings ($T_a=25^\circ\text{C}$)

Item	Symbol	Value	Unit
Power Dissipation	P_D	190	mW
Forward Current	I_F	50	mA
Pulse Forward Current *	I_{FP}	120	mA
Reverse Voltage	V_R	5	V
Operating Temperature	T_{opr}	-30 ... +85	$^\circ\text{C}$
Storage Temperature	T_{stg}	-40 ... +100	$^\circ\text{C}$
Soldering Temperature (5 sec.)	T_{sol}	260	$^\circ\text{C}$

* pulse width max. 10 ms, duty ratio max. 1/10

Unit: mm
Tolerance: ± 0.3 mm

Specifications ($T_a=25^\circ\text{C}$)

Item	Condition	Symbol	Min.	Typ.	Max.	Unit
Optical Specifications						
Luminous Intensity * ¹	$I_F = 50$ mA	I_V	25000	30000	-	mcd
Dominant Wavelength	$I_F = 50$ mA	λ_D	465	470	475	nm
Viewing Angle	$I_F = 50$ mA	$2\theta_{1/2}$	-	15	-	deg
Electrical Specifications						
Forward Voltage	$I_F = 50$ mA	U_F	3.0	3.3	3.8	V
Reverse Voltage	$U_F = 5$ V	U_R	-	-	10	μA

*¹ Tolerance of chromaticity coordinates is $\pm 10\%$

*² Tolerance of luminous intensity is $\pm 15\%$



Typical Performance Curves

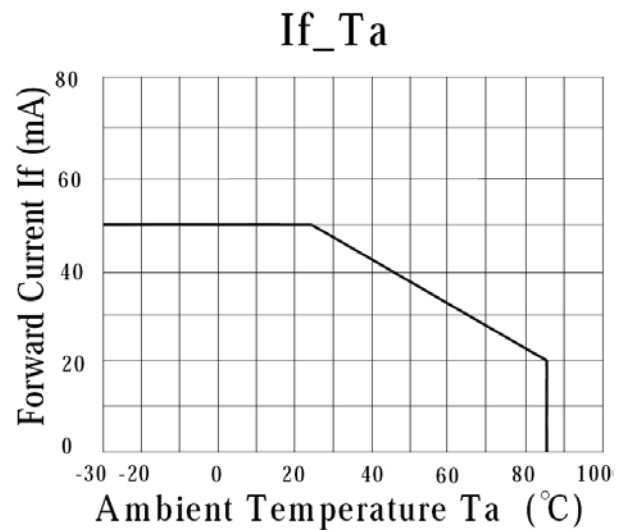
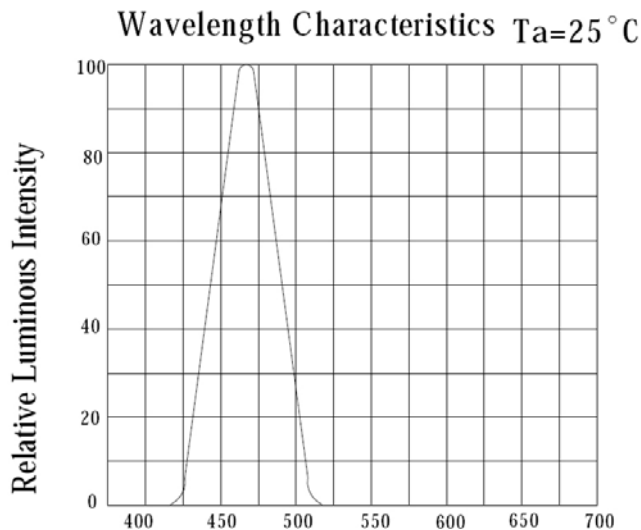
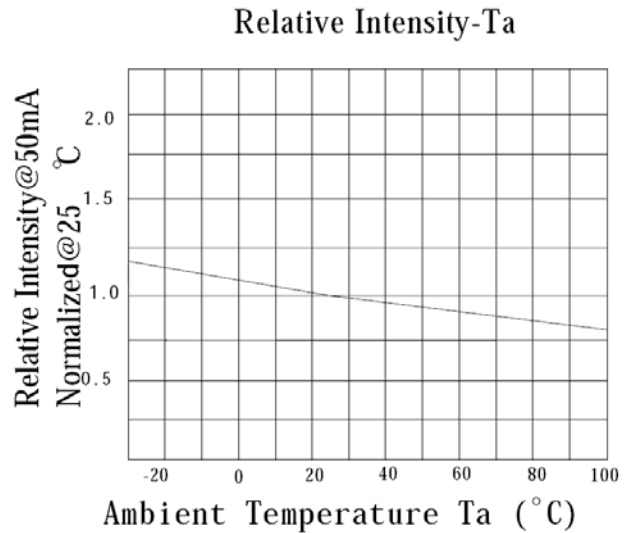
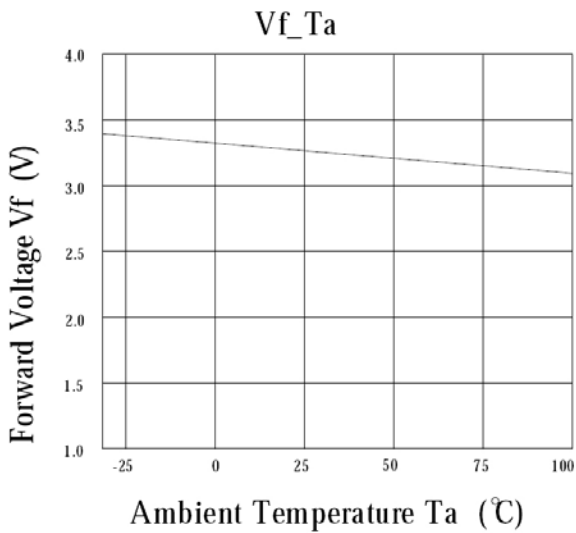
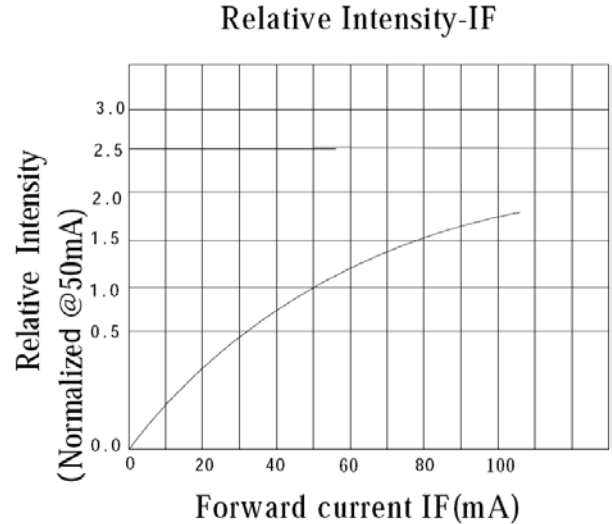
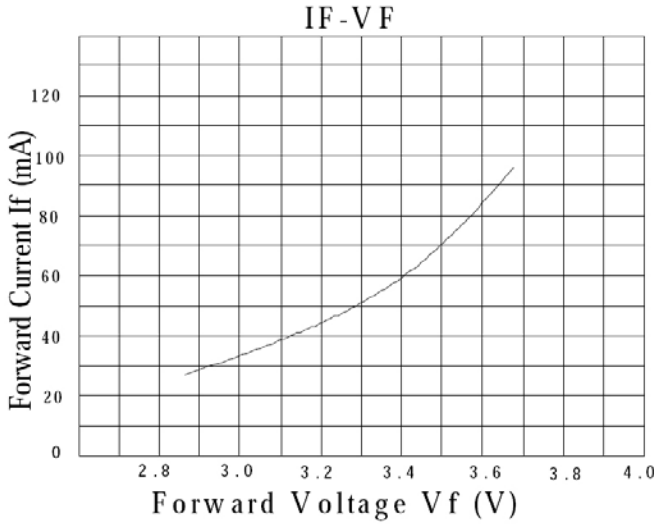



Reliability Test Report

Classification	Test Time	Test Condition
Endurance Test	Operation Life	$I_F = 50 \text{ mA}$ $T_a = 25 \pm 5 \text{ }^\circ\text{C}$ Test Time = 1000hrs (-24hrs, +72hrs)
	High Temperature High Humidity Storage	R.H = 90~95% $T_a = 65 \pm 5 \text{ }^\circ\text{C}$ Test Time = 240hrs (+2hrs)
	High Temperature Storage	$T_a = 105 \pm 5 \text{ }^\circ\text{C}$ Test Time = 500hrs (-24 hrs, +48hrs)
	Low Temperature Storage	$T_a = 55 \pm 5 \text{ }^\circ\text{C}$ Test Time = 500hrs (-24hrs, +48hrs)
Environmental Test	Temperature Cycling	$105 \text{ }^\circ\text{C} \sim 25 \text{ }^\circ\text{C} \sim 55 \text{ }^\circ\text{C} \sim 25 \text{ }^\circ\text{C}$ 60 min 10 min 60 min 10 min 20 cycles
	Thermal Shock	$105 \text{ }^\circ\text{C} \sim -55 \text{ }^\circ\text{C}$ 10 min 10 min 10 cycles
	Solder Resistance	$T_a = 260 \pm 5 \text{ }^\circ\text{C}$ Test Time = $10 \pm 1 \text{ sec}$
	Solderability	$T_a = 230 \pm 5 \text{ }^\circ\text{C}$ Test Time = $5 \pm 1 \text{ sec}$

Judgement Criteria Of Failure For The Reliability

Measuring Time	Symbol	Conditions	Failure
Luminous Intensity	I_V	$I_F = 50 \text{ mA}$	$I_V < 0.5 \cdot \text{Initial Value}$
Forward Voltage	U_F	$I_F = 50 \text{ mA}$	$U_F < 1.2 \cdot \text{Initial Value}$
Reverse Current	I_R	$U_F = 5 \text{ V}$	$I_R > 2 \cdot \text{Spec}$

Operation Life Test Luminance Rate Curve

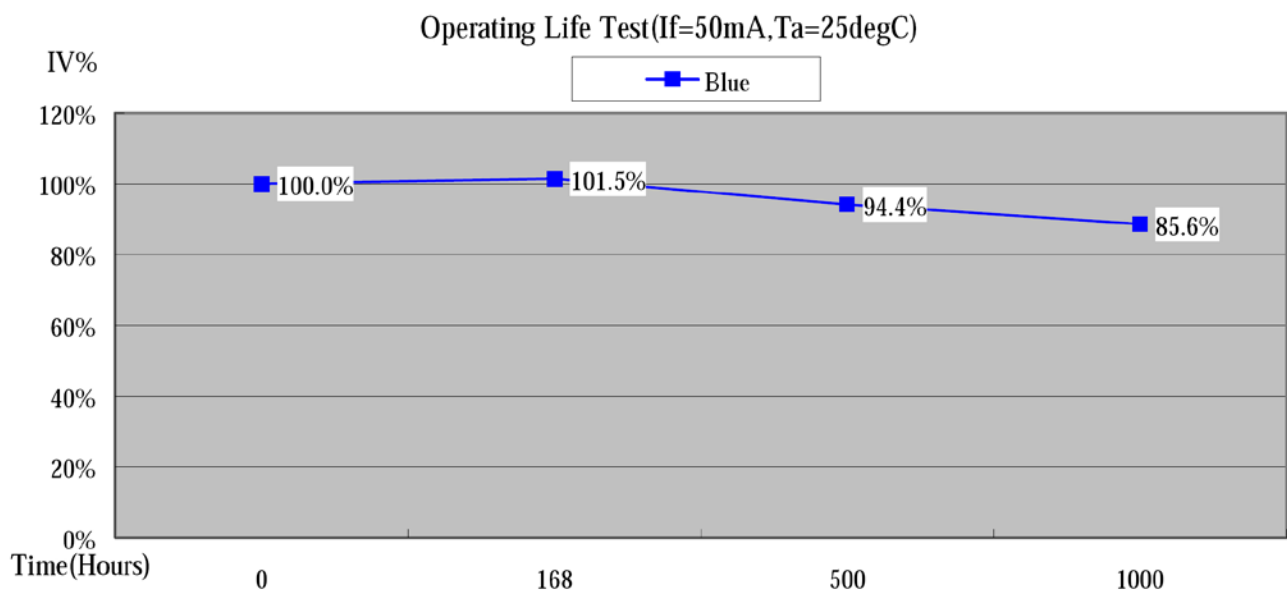

- * Brun-in condition: 50 mA
- * Projection of Statistical Average Light Output Degradation Performance for LED Technology Extrapolated from Test Data.
- * According to outgoing Packaged Products Specification
- * MTBF:100,000hrs, 90% Confidence (A Failure is Any LED Which is Open, shorted or fails to Emit Light)
- * The Projected Data is Base on The Feature of LED Itself Under Normal Operation Conditions.
- * Any Improper Circuit Design or External Factors Might Cause a Different Result.



Precaution for Use

1. Cautions

- DO NOT look directly into the light or look through the optical system.

2. Lead Forming

- When forming leads, the leads should be bent at a point at least 3 mm from the base of the lead. DO NOT use the base of the leadframe as a fulcrum during lead forming.
- Lead forming should be done before soldering.
- DO NOT apply any bending stress to the base of the lead. The stress to the base may damage the LED's characteristics or it may break the LEDs.
- When mounted the LEDs onto the printed circuit board, the holes on the circuit board should be exactly aligned with the leads of LEDs. If the LEDs are mounted with stress at the leads, it causes deterioration of the lead and it will degrade the LEDs.

3. Soldering Conditions

- Solder the LEDs no closer than 3 mm from the base of the lead.
- Recommended soldering conditions:

Dip Soldering	
Pre-Heat	120 °C Max.
Pre-Heat Time	60 Seconds Max.
Solder Bath Temperature	260 °C Max.
Dipping Time	5 Seconds Max.
Dipping Position	No lower than 3 mm from the base of the epoxy bulb

- DO NOT apply any stress to the lead particularly when heat.
- The LEDs must not be reposition after soldering.
- After soldering the LEDs, the lead should be protected from mechanical shock or vibration until the LEDs return to room temperature.
- When it is necessary to clamp the LEDs to prevent soldering failure, it is important to minimize the mechanical stress on the LEDs.
- Cut the LED leads at room temperature. Cutting the leads at high temperature may cause the failure of the LEDs.

4. Static Electricity

- The LEDs are very sensitive to Static Electricity and surge voltage. So it is recommended that a wrist band or an anti-electrostatic glove be used when handling the LEDs.
- All devices, equipment and machinery must be grounded properly. It is recommended that precautions should be taken against surge voltage to the equipment that mounts the LEDs.



5. Heat Generation

- The powered LEDs generate heat. Heat dissipation should be considered in the application design to avoid the environmental conditions for operation in excess of the absolute maximum ratings.