



ROITHNER LASERTECHNIK GmbH

WIEDNER HAUPTSTRASSE 76
TEL. +43 1 586 52 43 -O. FAX. -44

1040 VIENNA AUSTRIA
OFFICE@ROITHNER-LASER.COM



S8081000G

- IR Laser Diode
- 808 nm, 1000 mW
- Multi mode
- TO9 with integrated photodiode



Description

S8081000G is an IR laser diode, typically emitting at 808 nm, with a wide operating temperature range of up to 50°C, low operating current and low divergence angle. **S8081000G** comes in 9 mm TO-Can package with integrated monitor photodiode.

Maximum Rating* (T_{CASE} = 25°C)

| Parameter | Symbol | Values | | Unit |
|---------------------------------|-----------|--------|-------|------|
| | | Min. | Max. | |
| Optical Output Power*1 | P_{MAX} | | 1100 | mW |
| Reverse Voltage | V_R | | 2 | V |
| Operating Temperature*1 | T_{OPR} | - 10 | + 50 | °C |
| Storage Temperature | T_{STG} | - 10 | + 85 | °C |
| Soldering Temperature (max. 3s) | T_{SOL} | | + 260 | °C |

*1 operating at maximum ratings may influence the life time

Electro-Optical Characteristics (T_{CASE} = 25°C)

| Parameter | Symbol | Values | | | Unit |
|------------------------|---------------|------------------|------|------|------|
| | | Min. | Typ. | Max. | |
| Peak Wavelength | λ_P | 803 | 808 | 813 | nm |
| Optical Output Power | P_O | | 1000 | | mW |
| Operating Voltage | V_F | | 2.0 | 2.2 | V |
| Threshold Current | I_{th} | | 220 | | mA |
| Operating Current | I_F | | 1200 | 1500 | mA |
| Monitor Current | I_M | | 0.9 | | mA |
| Slope Efficiency | η | 0.95 | 1.1 | | W/A |
| Beam Divergence (FWHM) | parallel | $\Theta_{ }$ | 8 | | deg. |
| | perpendicular | Θ_{\perp} | 28 | | deg. |



Electrical Connection

Pin Configuration

| Pin # | Function |
|-------|----------------------|
| Pin 1 | PD Anode |
| Pin 2 | LD Cathode |
| Pin 3 | LD Anode, PD Cathode |

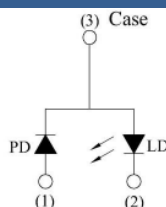

Bottom View

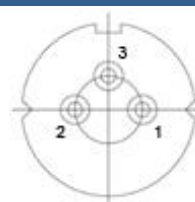



Performance Characteristics

Optical Output Power vs. Forward Current

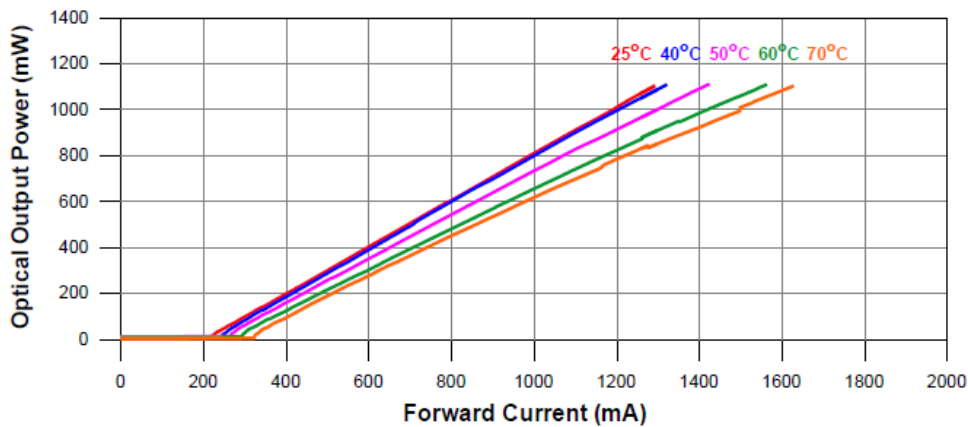

Forward Voltage vs. Forward Current

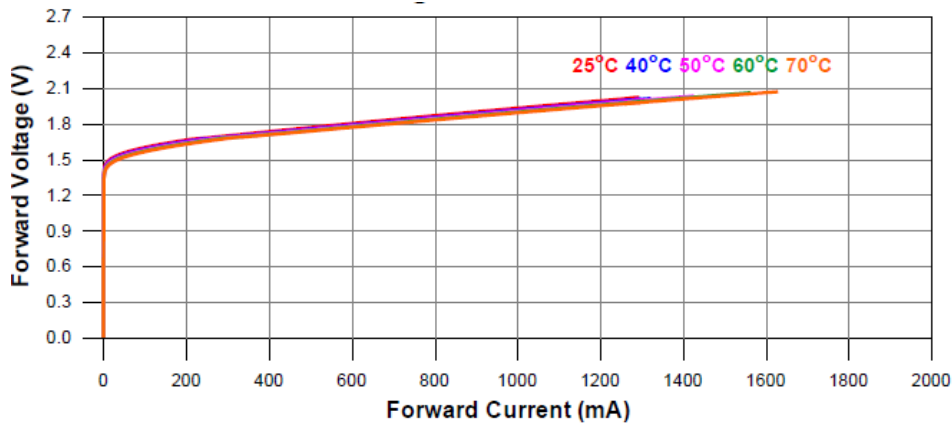

Peak Wavelength vs. Case Temperature

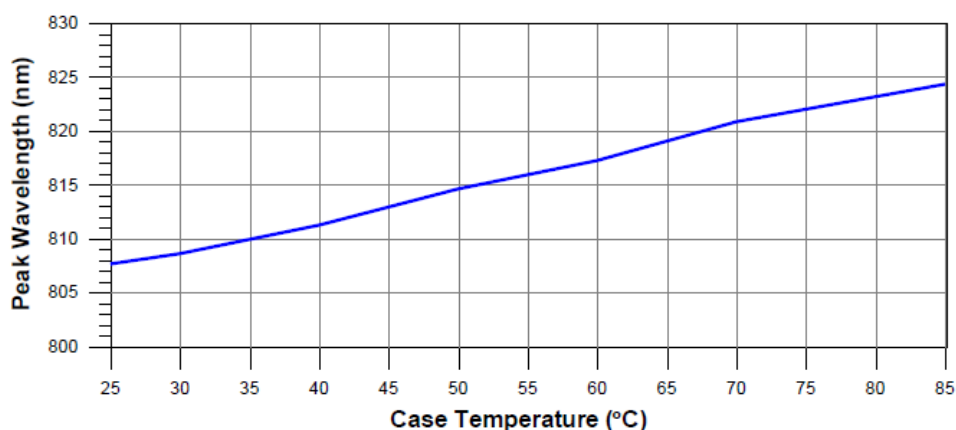



Performance Characteristics

Far-Field Pattern

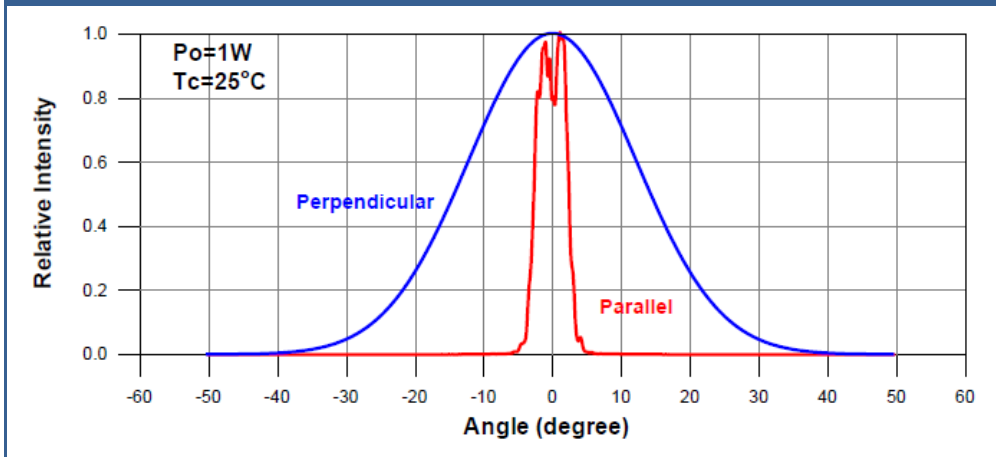

Slope Efficiency vs. Case Temperature

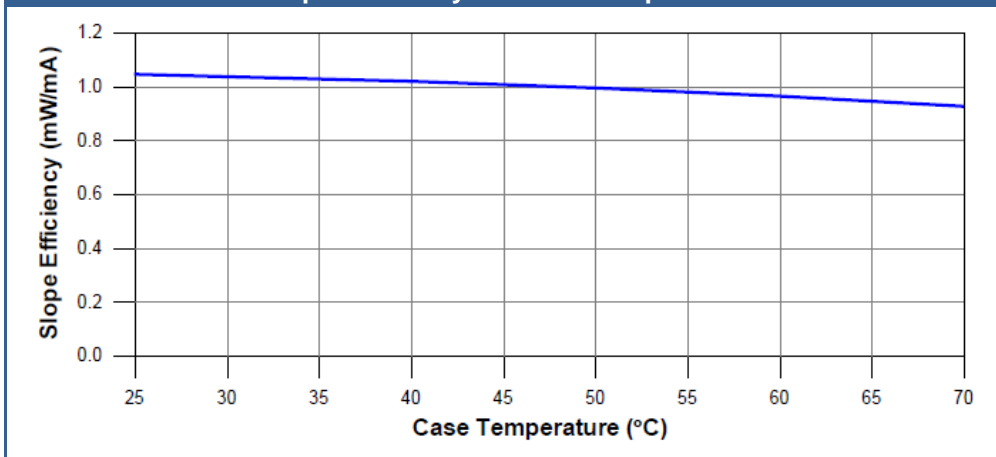

Monitor Current vs. Optical Output Power

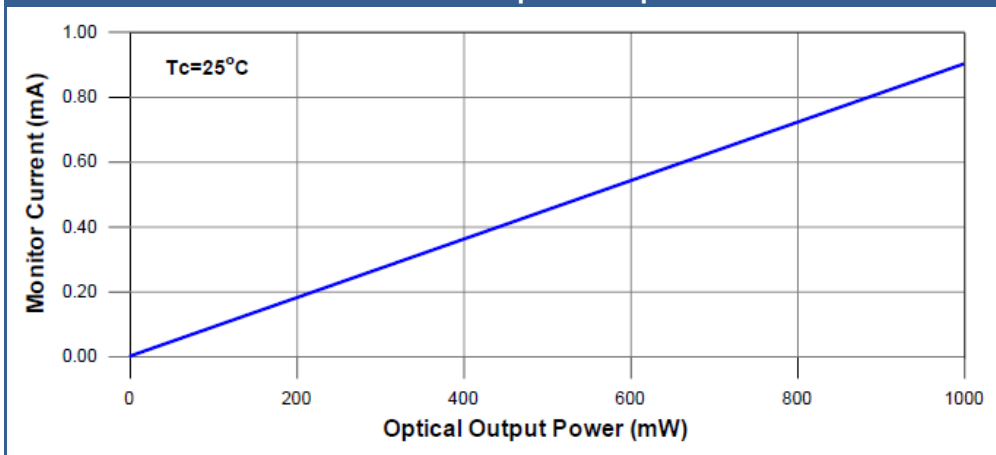



Outline Dimensions

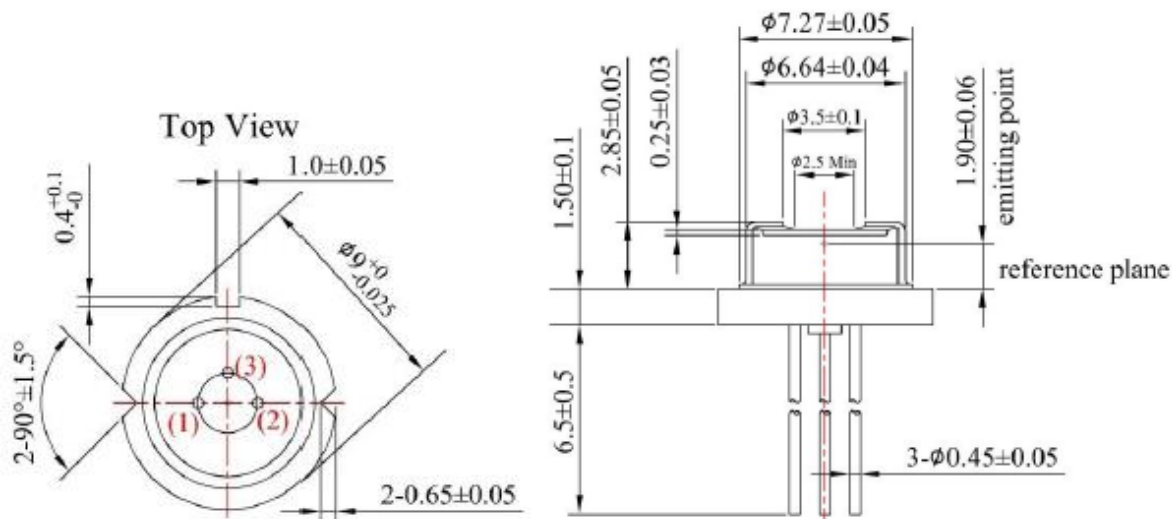

All dimensions in mm

Precautions

Safety

Caution: Laser light emitted from any laser diode may be **harmful to the human eye**. Avoid looking directly into the laser diode's aperture when the diode is in operation.

Note: The use of optical lenses with this laser diode will increase eye hazard

ESD caution

Always do handle laser diodes with extreme care to **prevent electrostatic discharge**, the primary cause of unexpected diode failure. To prevent ESD related failures, it is strongly advised to always **wearing wrist straps**, and **grounding all applicable work surfaces**, when handling laser diodes

Operating Considerations

It is strongly advised to only operate this laser diode with a current source. The current of a laser diode is an exponential function of the voltage across it. **Usage of current regulated drive circuits is mandatory.** Laser diodes may be damaged by excessive drive currents or switching transients

It is advised, to operate the laser diode at the lowest temperature possible, and to never exceed maximum specifications as outlined in the datasheet. Device degradation will accelerate with increased temperature. **Proper heat sinking will greatly enhance stability and life time of the laser diode**