



## ADL-66302TL



### TECHNICAL DATA

## Red Laser Diode

#### Features

- AlGaAs laser diode
- Peak Wavelength: 658 nm
- Optical Output Power: 30 mW
- Package: 5.6 mm, with Photo Diode



#### Electrical Connection

Pin Configuration	Bottom View								
<p>m-type</p> <table border="1"> <thead> <tr> <th>PIN</th> <th>Function</th> </tr> </thead> <tbody> <tr> <td>1</td> <td>LD Cathode</td> </tr> <tr> <td>2</td> <td>LD Anode, PD Cathode</td> </tr> <tr> <td>3</td> <td>PD Anode</td> </tr> </tbody> </table>	PIN	Function	1	LD Cathode	2	LD Anode, PD Cathode	3	PD Anode	
PIN	Function								
1	LD Cathode								
2	LD Anode, PD Cathode								
3	PD Anode								

#### Absolute Maximum Ratings ( $T_C=25^\circ\text{C}$ )

Item	Symbol	Value	Unit
Optical Output Power	$P_O$	35	mW
LD Reverse Voltage	$V_R$ (LD)	2	V
PD Reverse Voltage	$V_R$ (PD)	30	V
PD Forward Current	$I_{PD}$	10	mA
Operating Case Temperature	$T_C$	-10 ... +60	$^\circ\text{C}$
Storage Temperature	$T_{stg}$	-40 ... +85	$^\circ\text{C}$

#### Specifications ( $T_C=25^\circ\text{C}$ )

Item	Symbol	Min.	Typ.	Max.	Unit
<b>Optical Specifications</b>					
Optical Output Power (CW)	$P_O$	-	30	-	mW
Peak Wavelength	$\lambda_P$	650	658	665	nm
FWHM Beam Divergence	$\Theta_{\parallel}$	6.0	7.5	12.0	deg
	$\Theta_{\perp}$	14	17	22	deg
Emission Point Accuracy	Angle	$\Delta\theta_{\parallel}$	-3	+3	deg
		$\Delta\theta_{\perp}$	-3	+3	deg
Astigmatism	$A_s$	-80	-	+80	$\mu\text{m}$
<b>Electrical Specifications</b>					
Threshold Current	$I_{th}$	-	45	60	mA
Operating Current	$I_{op}$	-	70	90	mA
Slope Efficiency	$\eta$	0.7	1.0	1.4	W/A
Operating Voltage	$V_{op}$	2.0	2.5	3.0	V
Monitor Current	$I_m$	0.05	0.15	0.30	mA

The above specifications are for reference purpose only and subjected to change without prior notice.



## Package Dimensons

### 5.6 mm Package (Unit:mm)

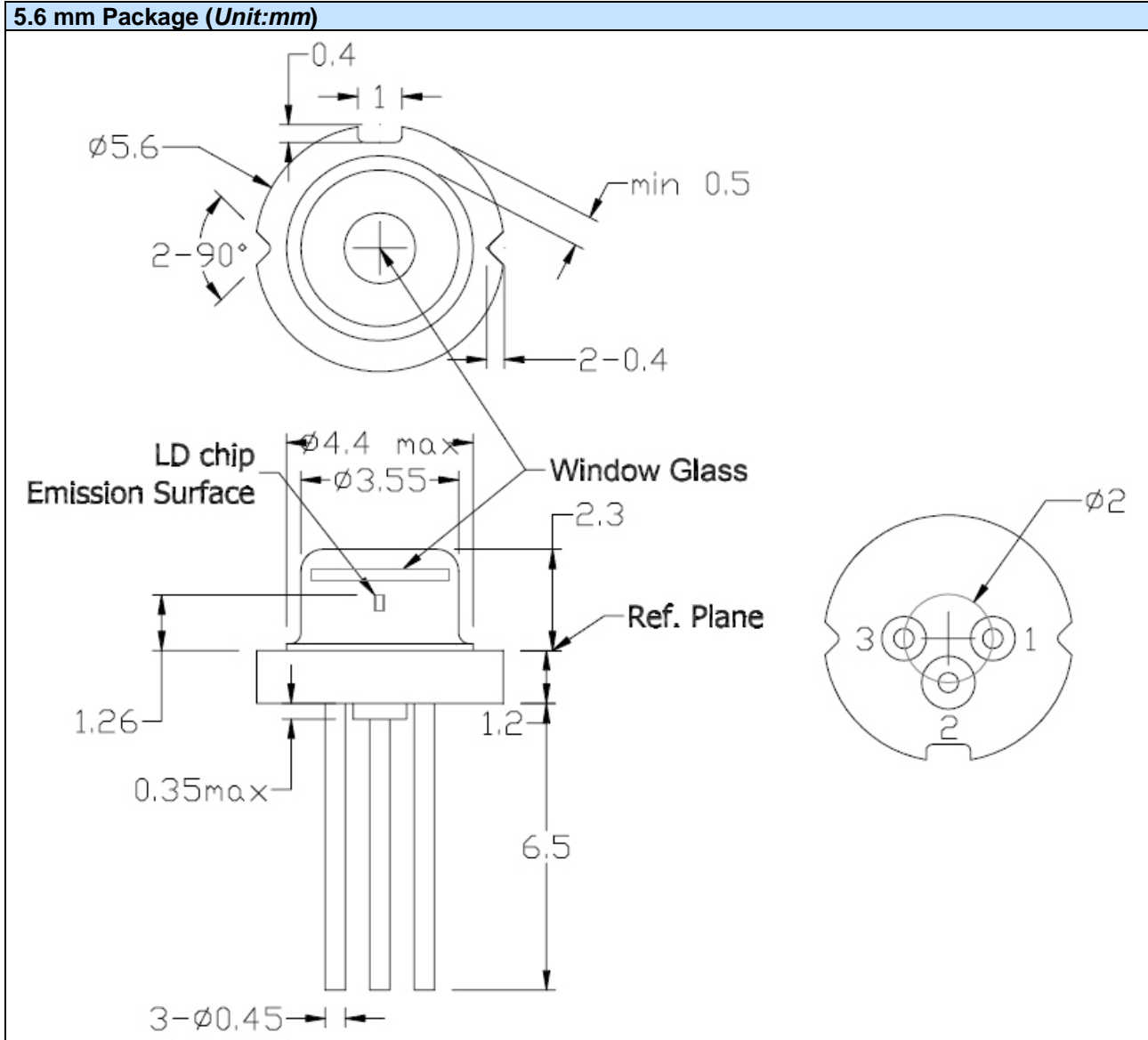



## Typical Performance Curves

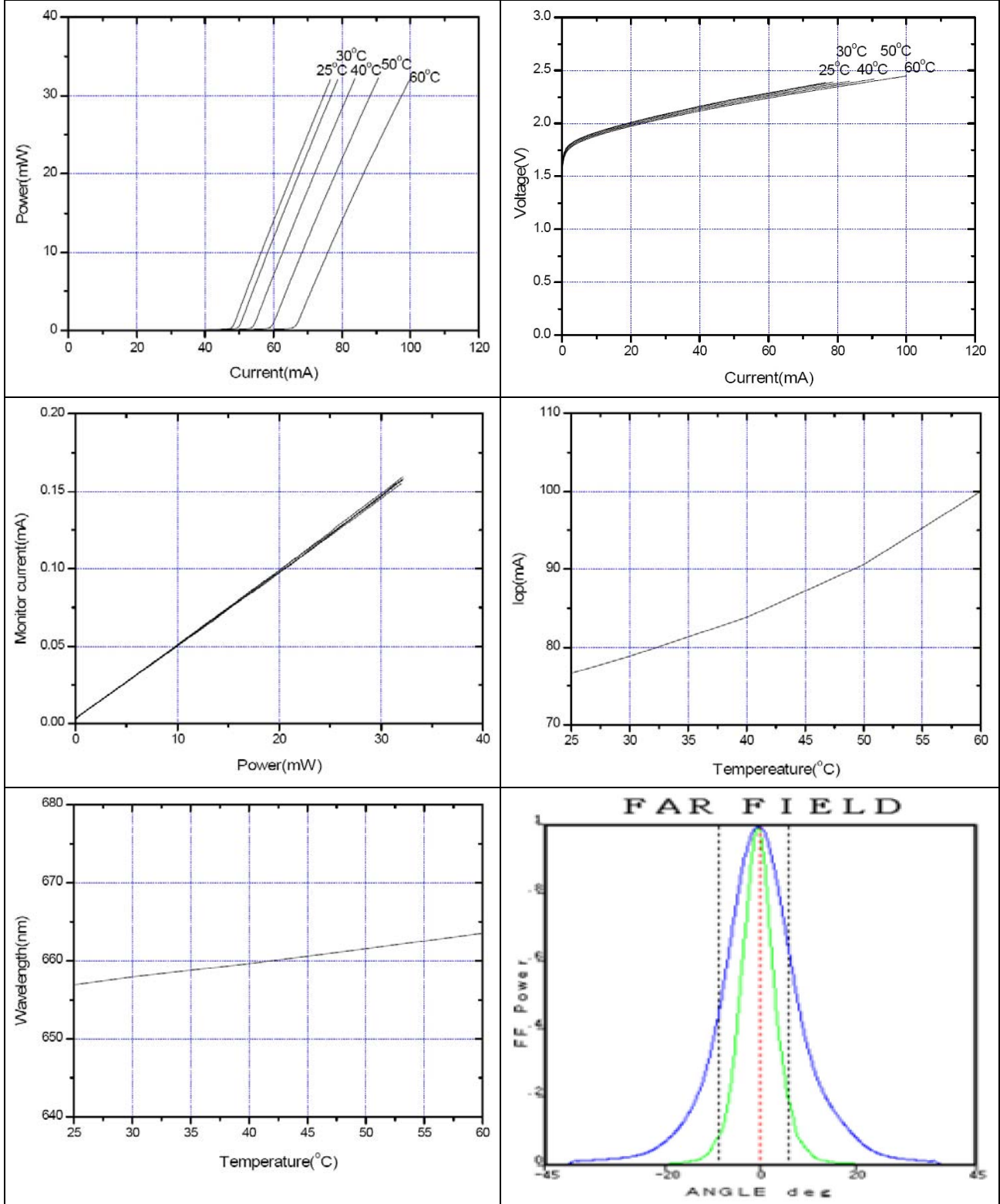



## Safety of Laser light

- Laser Light can damage the human eyes and skin. Do not expose the eye or skin directly to any laser light and/or through optical lens. When handling the LDs, wear appropriate safety glasses to prevent laser light, even any reflections from entering to the eye. Focused laser beam through optical instruments will increase the chance of eye hazard.



## Cautions

### 1. Operating methode

- This LD shall change its forward voltage requirement and optical output power according to temperature change. Also, the LD will require more operation current to maintain same output power as it degrades. In order to maintain output power, use of APC (Automatic Power Control) is recommended. Which use monitor feedback to adjust the operation current.
- Confirm that electrical spike current generated by switching on and off does not exceed the maximum operating current level specified herein above as absolute maximum rating. Also, employ appropriate countermeasures to reduce chattering and/or overshooting in the circuit.

### 2. Static Electricity

- Static electricity or electrical surges will reduce and degrade the reliability of the LDs. It is recommended to use a wrist trap or anti-electrostatic glove when handling the product.

### 3. Absolute Maximum Rating

- Active layer of LDs shall have high current density and generate high electric field during its operation. In order to prevent excessive damage, the LD must be operated strictly below absolute maximum rating.



**NOTE**  
LASERDIODE  
MUST BE COOLED